

# CRL

## Central Research Laboratories

a DESTACO company



## Telemanipulators

*Visual Selection Guide*



### ***A Legacy of Innovative Experience***

In 1945, at the dawn of the Atomic Age, three scientists from the Massachusetts Institute of Technology founded Central Research Laboratories (CRL) and pioneered early development of safer methods for handling hazardous and toxic products produced by this industry. With a legacy of over 70 years of innovative experience, CRL has continued to develop and build a full line of remote handling and containment solutions including Telemanipulators, Transfer Systems, Glove Ports, and Waste Drum Transfer Systems. These products allow operators to safely and efficiently perform various tasks in Nuclear and Life Science industries across the world.

The CRL team has the experience, expertise, and technologies to help with all your remote handling needs and strives to continually improve and develop innovative technology that help its customers achieve the highest level of performance. CRL is committed to its customers' needs and developing the best solutions for every project. Every product manufactured is created with those specific needs in mind to deliver the most customized solution available for every application.

---

***crlsolutions.com***

*Central Research*  
**laboratories**

RED WING, MINN.

***Proven Technology. Customized Solutions.***

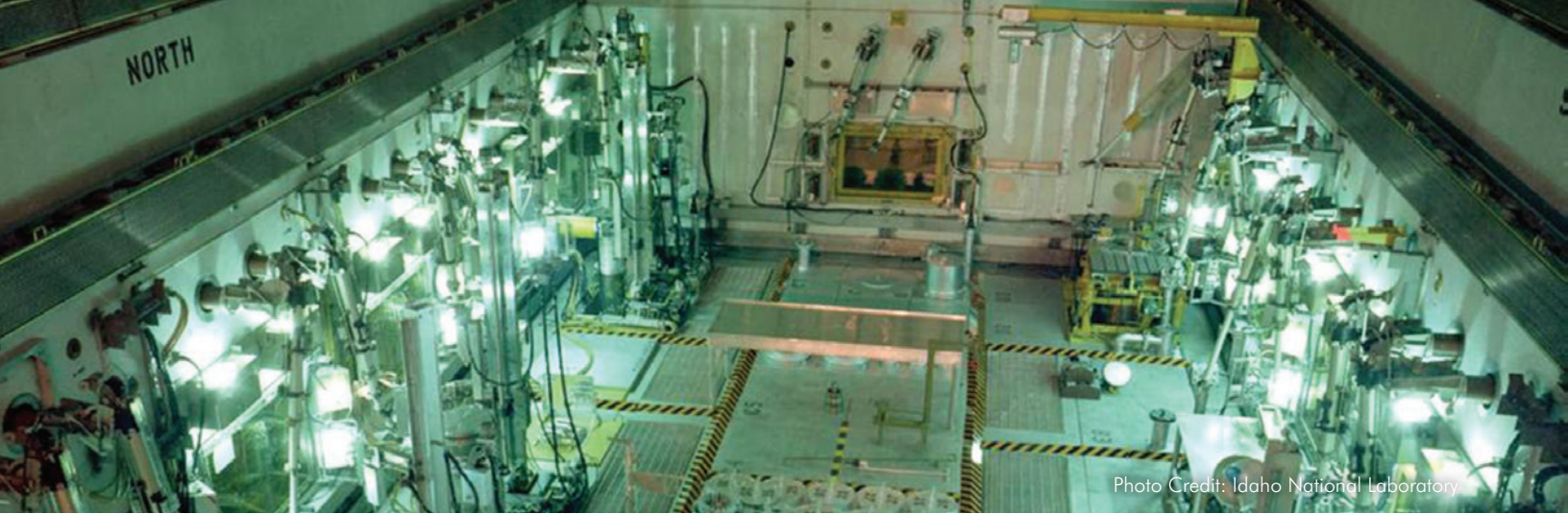

Photo Credit: Idaho National Laboratory

## ***Proven Technology Customized for Your Specific Needs***

**For over 75 years CRL has been a trusted manufacturer of telemanipulators. Today, our experienced experts continue to deliver customized and innovative solutions to meet evolving industry needs.**

CRL Telemanipulators extend the dexterous manipulative capabilities of a human operator remotely into a high radiation or hazardous environment. Typical tasks range from operation of laboratory instruments to the maintenance of large process equipment, all requiring dexterous manipulations. These tasks are unstructured and require real-time human intervention.

Natural motions of the hands at the command end are reproduced identically at the remote end. These operations are accomplished with a minimum of effort and a maximum of precision due to careful counter-balancing and reduction of mass, friction and lost motion. Very little force is required to initiate and maintain uniform motion in any horizontal or vertical direction.

### **One-Piece Telemanipulator**

The one-piece telemanipulator is the most widely used and consists of a command arm, remote arm, and through-the-wall tube assembled as one unit. Stainless steel tapes and cables are used to transmit motions from the command arm to the remote arm in continuous closed loops. The single unit telemanipulator is installed and removed in the hot cell from the operator's side.

The installation is accomplished by indexing the remote arm to a position in line with the wall tube, inserting the telemanipulator into the wall sleeve, then indexing the remote arm down to an operating position inside the hot cell. The single unit telemanipulator is typically used when the in-cell atmosphere is air instead of an inert gas. Typically the atmosphere in-cell is at a negative pressure for one-piece telemanipulators. An optional booting assembly can be added to protect the remote arm from contamination.

### **Three-Piece Telemanipulator**

The three-piece telemanipulator is typically used in an inert atmosphere cell, which requires careful environmental control. Typically the in-cell atmosphere is at a negative pressure for three-piece telemanipulator applications. The three-piece telemanipulator consists of three independent assemblies, the command arm, the remote arm and the through-the-wall tube (seal tube).

The command arm is removable and interchangeable with any seal tube. The remote arm is remotely removable with an in-cell crane and is also interchangeable with any seal tube. The seal tube is maintenance free and usually remains in the wall. When using a three-piece telemanipulator, provisions should be made to remove the remote arm from the hot cell through an air lock or transfer port for maintenance. The three-piece telemanipulator may also be installed and removed from the operator side similar to the single unit telemanipulator.

**One-Piece Telemanipulator**

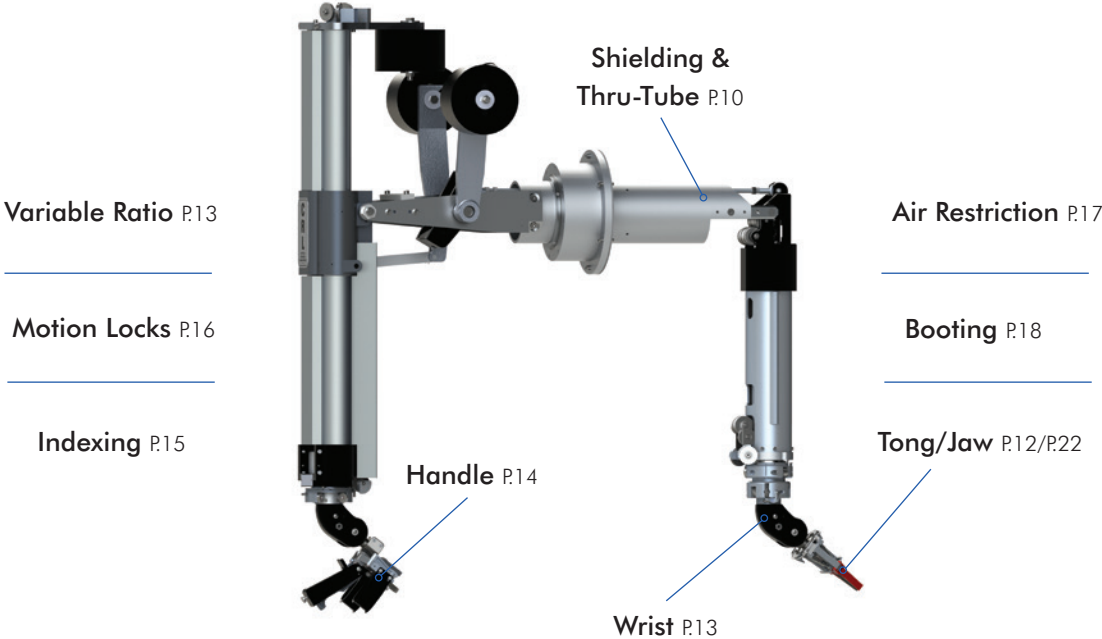

**Three-Piece Telemanipulator**

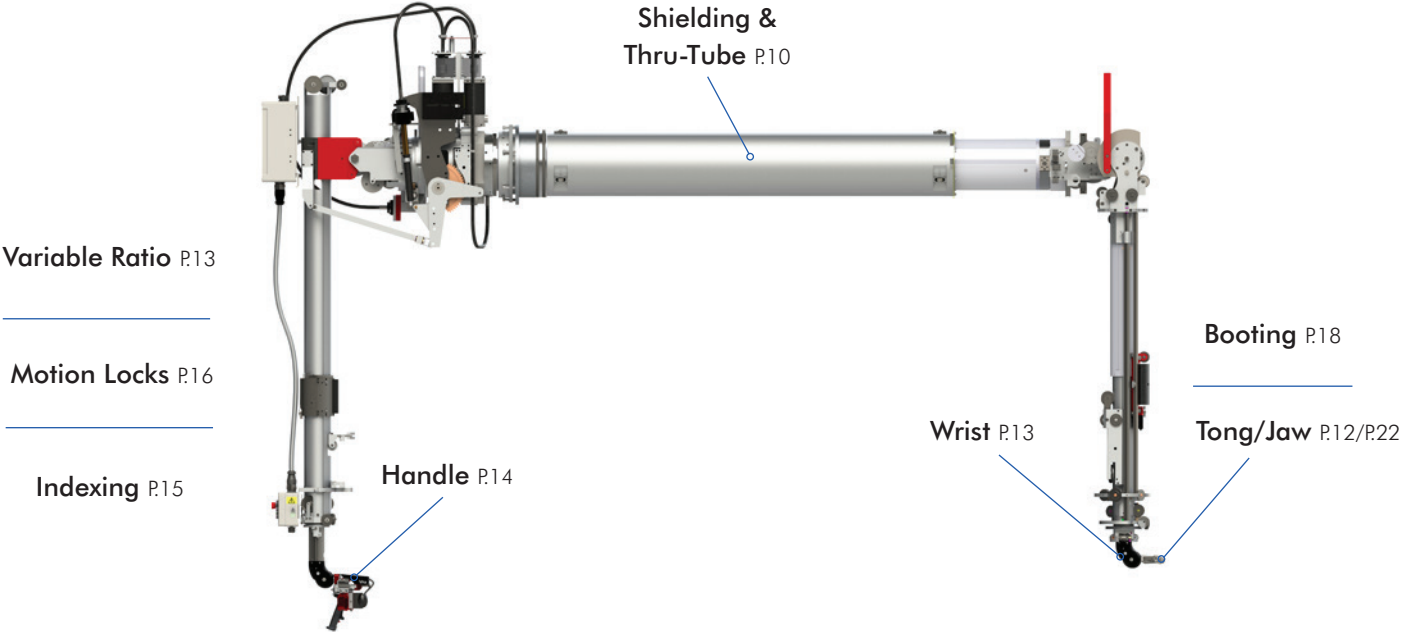

# TABLE OF CONTENTS



Telescreen Model Overview..... 6



Telescreen Specification Guide ..... 8



Radiation Shielding and Thru-Tube ..... 10



Tong/Jaws ..... 12



Wrist ..... 13



Variable Ratio..... 13



Handle ..... 14

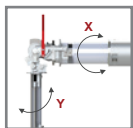

Indexing ..... 15



Motion Locks ..... 16



Air Restriction ..... 17



Booting ..... 18

**Accessories**



Installation/Removal Carts..... 20

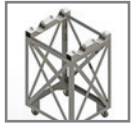

Storage Cart ..... 20



Tamper Lock ..... 21



Load Hook..... 21



Change Fixture..... 21

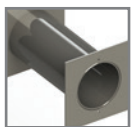

Wall Tubes ..... 21



Jaws..... 22

### Telemanipulator Selection Guide

CRL produces many different types of telemanipulators that are designed for many different working environments and uses. The following selection guide will give you a good starting point in specifying your telemanipulator using the loads that are intended to be worked on, and the amount of use they will see.

**DUTY CYCLE** Intermittent: Short, intermittent periods of time | Continuous: Constant use

**CELL SIZE** Small: Glovebox | Medium: Slightly larger working area; may require indexing to reach all areas comfortably  
Large: Large hot cell

ONE-PIECE TELEMANIPULATOR						
MAX. CAPACITY	MODEL	DUTY CYCLE		CELL SIZE		
		Intermittent	Continuous	Small	Medium	Large
10 lb (4.5 Kg)	G-LDR	✓		✓		
	G-LD		✓	✓		
	H		✓	✓		
	G		✓		✓	
20 lb (9 Kg)	G-HD		✓		✓	
	E		✓			✓
	8		✓		✓	
50 lb (22.6 Kg)	E-HD		✓			✓
	8-HD		✓		✓	
100 lb (45.3 Kg)	F		✓			✓

THREE-PIECE TELEMANIPULATOR						
MAX. CAPACITY	MODEL	DUTY CYCLE		CELL SIZE		
		Intermittent	Continuous	Small	Medium	Large
10 lb (4.5 Kg)	L	✓		✓		
20 lb (9 Kg)	L-HD		✓		✓	
	VERSA® MD		✓			✓
50 lb (22.6 Kg)	VERSA® HD		✓			✓

## Telemanipulator Motion Options Guide

Telemanipulator motions can be driven through the unit using stainless steel tape, aircraft-quality stainless steel cable or roller chain, depending on feel, load and longevity requirements.

See p.11 (FEEL description) for more detailed information on cable, tape and chain options.

**C**=Cable / **T**=Tape / **R**=Chain / **C/R**=Cable & Chain / **T/C**=Tape & Cable / **T/R**=Tape & Chain

MOTIONS								
MODEL	Z		AZIMUTH		ELEVATION/ TWIST		TONG	
	Standard	Available	Standard	Available	Standard	Available	Standard	Available
<b>G-LDR</b>	C		C		C		C	
<b>G-LD</b>	C	T	C		T	C	C	C/R
<b>H</b>			C		C		C	
<b>G</b>	C	T	C		T		C	C/R
<b>G-HD</b>	C		C		C		C	C/R
<b>E</b>	T	C	C		T		T	
<b>8</b>	T	C	C		T	C	T	C
<b>E-HD</b>	T	C	C		T	T/R	T/C	T/R
<b>8-HD</b>	T	C	C		T	C	T	
<b>F</b>	T		T		T		T/C	
<b>L</b>	T	C	C		T		T/C	
<b>L-HD</b>		C	C		C/R		C	C/R
<b>VERSA® MD</b>	T		C		T		T	
<b>VERSA® HD</b>	T		C		T		T	

# TELEMANIPULATOR SPECIFICATION GUIDE

The image below shows the typical dimensions of the hot and cold side of the cell required to specify the physical size requirements for a telemanipulator. Use this form and work with your local CRL Sales Representative to help select the proper telemanipulator size and options for your cell and applications.

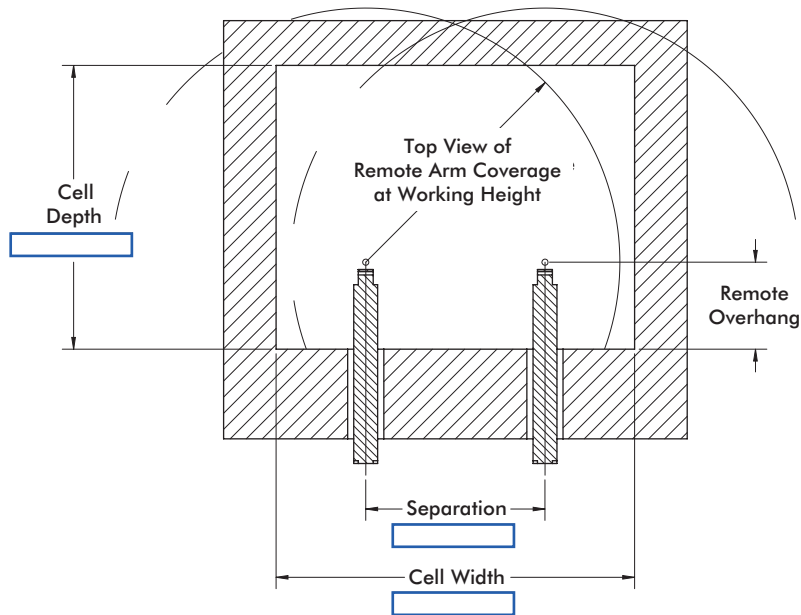
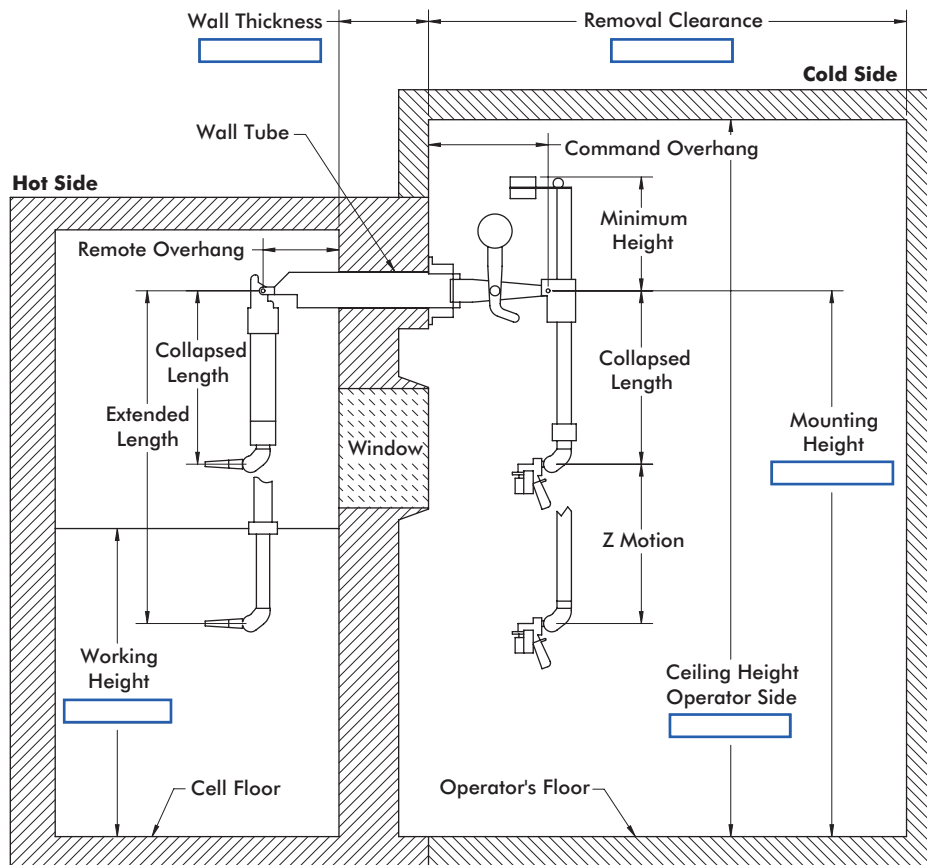

## Recommended, Available and Not Available Options

✓		✓ Recommended
●		● Available
✗		✗ Not Available

**Recommended:** These options are recommended and work best with the specified models

**Available:** These options are available for the specified models

**Not Available:** These options are not available or suited for the specified models

## Price, Usage and Feel Ratings

### PRICE



**Lowest:** Higher volume; Lowest cost solution

**Midgrade:** Requires special material or some customization

**Premium:** Requires high grade, special material and customization or extra components

### USAGE



Related to the Duty Cycle, Intermittent use telemanipulators are meant to be used for short, intermittent periods of time, not continuously. Continuous cycle telemanipulators are designed for constant use. Heavy Duty cycle telemanipulators can work continuously, and are designed for Demolition and Decontamination (D&D) and higher weight capacity in mind.

### FEEL



A telemanipulator's "feel" is a combination of how smooth and precise everything moves and the frictions of that movement. A light feeling telemanipulator will be very easy to move in all motions, but will generally be lower capacity or use all tape motion transmission. Medium feeling telemanipulators will start to incorporate cables, and chains in the wrist joints for durability. Heavy feeling arms are still smooth, but are all cable with chain wrist joints, and are generally high capacity arms focusing less on feel and more on durability and capacity.

## Radiation Shielding and Thru-Tube

Lead or Steel shielding can be provided in the telemanipulator thru-tube to match the lead equivalence of the cell wall, and Boronated Polyethylene can be provided for neutron absorption when required. The shielding is mounted in and/or around the telemanipulator thru-tube and is normally located so it is centered in the cell wall. The internal thru-tube shielding and external thru-tube to wall tube shielding configurations can be provided as shown below:

### Thru-Tube Shielding Laminated Design:

- Straight tie rods pass thru aligned slots in internal shielding pieces.

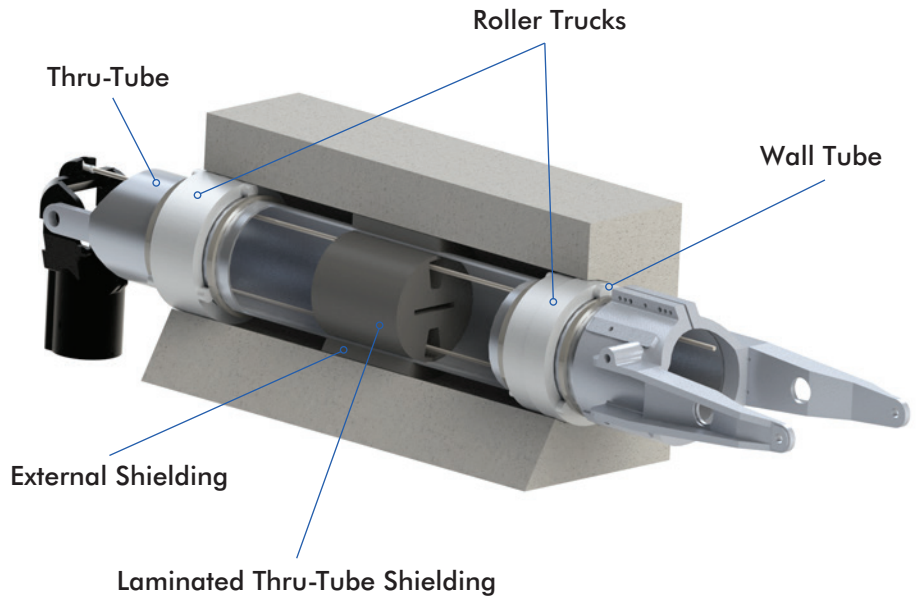

### Thru-Tube Shielding Labyrinth Design:

- Staggered tie rods pass thru staggered slots in internal shielding, minimizing potential shine path.

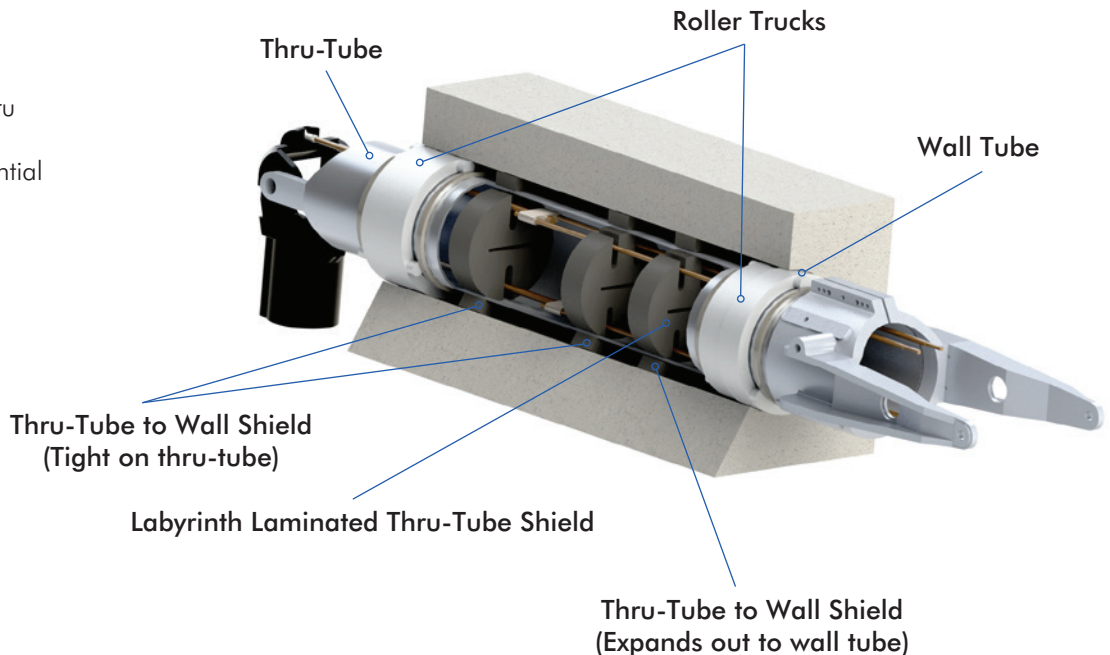

**Internal Shielding**

**Laminated**

✓	G-LDR, G-LD, G, H
●	G-HD, L, R, VERSA®, 8, E, E-HD, F
✗	

Lead

◆  
PRICE

Stainless Steel

◆◆  
PRICE

Boronated Poly

◆◆  
PRICE

**Labyrinth**

✓	E, E-HD, F
●	G-HD, G, L, R, VERSA®, 8
✗	G-LDR, G-LD, H

Lead

◆◆  
PRICE

Stainless Steel

◆◆◆  
PRICE

Boronated Poly

◆◆◆  
PRICE

**External Shielding**

**Laminated**

✓	G, G-LD, G-HD, H, 8, E, E-HD, F
●	G-LDR, R, VERSA®
✗	L

Lead

◆  
PRICE

Stainless Steel

◆◆  
PRICE

Boronated Poly

◆◆  
PRICE

**Labyrinth**

✓	G, G-HD, E, E-HD, 8, F
●	R, VERSA®
✗	G-LDR, G-LD, H, L

Lead

◆◆  
PRICE

Stainless Steel

◆◆◆  
PRICE

Boronated Poly

◆◆◆  
PRICE

**Penetration Hole Size**

**Ø4.76 in (120.9 mm)**

G-LDR only

**Ø7.5 in (190.5 mm)**

G-LD, G-HD, L, H

**Ø10 in (254 mm)**

E, E-HD, F, 8,  
8-HD, L-HD, VERSA®

**Custom**

## Tong Jaw

A variety of tong jaw options are available to handle the type of load that is required to be manipulated. Various jaws are available for both types to handle various shapes and types of loads.

A load hook is available to move the heaviest of loads without damaging the wrist joint and tapes/cables.



### SRL Tong

- Heavy Duty Applications
- Interchangeable Jaws

✓	E-HD, F, VERSA®, 8-HD, G-HD, L-HD
●	G, 8, E, L, H
✗	G-LDR

### Aluminum

◆◆	◆◆	◆◆
PRICE	USAGE	FEEL

### Stainless Steel

◆◆◆	◆◆◆	◆◆
PRICE	USAGE	FEEL



### RCD Tong

- Light Duty Applications
- Interchangeable Tong

✓	G-LDR, G, G-LD, L
●	H, E, 8
✗	F, 8-HD, E-HD, VERSA®, G-HD, L-HD

### Aluminum

◆◆	◆	◆◆◆
PRICE	USAGE	FEEL

### Stainless Steel

◆◆◆	◆◆	◆◆◆
PRICE	USAGE	FEEL



### Power Tong

- Heavy Duty Applications
- Interchangeable Jaws
- Requires full Power Tong system for use (additional cost)

✓	
●	VERSA® HD
✗	All other telemanipulators

### Aluminum

◆◆◆	◆◆◆	◆◆
PRICE	USAGE	FEEL

### Stainless Steel

◆◆◆	◆◆◆	◆◆
PRICE	USAGE	FEEL



2-piece Tong



3-piece Tong

### Small 2-piece or 3-piece Tong

- Light Duty Applications where a sealed tong is required

✓	L, L-HD, G, G-HD
●	H, E, VERSA® MD
✗	E-HD, F, VERSA® HD

◆◆◆	◆◆	◆◆◆
PRICE	USAGE	FEEL

### Large 2-piece or 3-piece Tong

- Heavy Duty Applications where a sealed tong is required

✓	E-HD, F, VERSA® HD
●	
✗	All other telemanipulators

◆◆◆	◆◆◆	◆◆
PRICE	USAGE	FEEL

## Wrist

The wrist joint is a collection of gears, bevel gears, bearing, and pulleys. They mesh together to give the telemanipulator the hand-like motion that are their trademarks. On a remote arm, the wrist and tong area of a telemanipulator gets the most contaminated. Sometimes having special tongs or wrist joints might help with a tricky job. The Removable Wrist joint will help with those special cases where a standard tong/wrist is problematic.



### Removable Wrist

✓	
●	VERSA®, E-HD, F
✗	All other telemanipulators



Removable Wrist  
(Shown removed)

### Tape

◆◆◆	◆◆	◆◆◆
PRICE	USAGE	FEEL

### Cable

◆◆◆	◆◆	◆◆
PRICE	USAGE	FEEL

### Chain

◆◆◆	◆◆◆	◆
PRICE	USAGE	FEEL



### Non-Removable Wrist

✓	All telemanipulators
●	
✗	

### Tape

◆◆	◆◆	◆◆◆
PRICE	USAGE	FEEL

### Cable

◆◆	◆◆	◆◆
PRICE	USAGE	FEEL

### Chain

◆	◆◆◆	◆
PRICE	USAGE	FEEL

## Variable Ratio

Sometimes it is advantageous to move the remote arm further than the command arm is moved in 'Z' motion. This also allows a telemanipulator to cover a larger hot cell for a given command arm.

### Variable Ratio

- Ratios available are 4:3, 1.5:1

✓	
●	G, G-HD
✗	All other telemanipulators

X	Y	Z
◆◆◆	◆◆◆	◆◆◆
PRICE	PRICE	PRICE
◆◆◆	◆◆◆	◆◆◆
FEEL	FEEL	FEEL

## Handles

CRL can provide a variety of handles chosen for operation comfort and efficiency. All handles shown can be operated with either hand and are not interchangeable on the telemanipulator without major disassembly.



### Opposed Grip

- Used for Light Handling

✓	G-LDR, G-LD, G, L, E, 8, H
●	G-HD, L-HD, VERSA® MD
✗	E-HD, F, VERSA® HD, 8-HD

◆ PRICE | ◆ USAGE | ◆◆◆ FEEL



### Pistol Grip

- Used for Heavy Handling

✓	
●	All other telemanipulators
✗	G-LDR

1-Speed ◆◆ PRICE | ◆◆◆ USAGE | ◆◆ FEEL

✓	F, VERSA® HD
●	E-HD, 8-HD
✗	G-LDR, G-LD, G, G-HD, L, L-HD

2-Speed (Ratchet) ◆◆◆ PRICE | ◆◆◆ USAGE | ◆◆ FEEL



### Motion Grip

- Used for Heavy Handling

✓	G-HD, L-HD, VERSA® MD
●	G-LDR, G, L, E, 8
✗	F, VERSA® HD, E-HD

◆◆ PRICE | ◆◆◆ USAGE | ◆◆ FEEL



### VERSA® VR8

- Improved ergonomics for operator comfort; **easily interchangeable**

✓	G-LDR, G, L, E, 8, H, VERSA® MD
●	G-LD, G-HD, L-HD
✗	E-HD, F, VERSA® HD, 8-HD

Opposed Grip ◆◆ PRICE | ◆◆ USAGE | ◆◆◆ FEEL

✓	F, VERSA® HD, E-HD	AVAILABLE SOON!
●	G-HD, L-HD, VERSA® MD	
✗	G-LDR, G, L, E, 8	

Pistol Grip ◆◆◆ PRICE | ◆◆◆ USAGE | ◆◆ FEEL



### Power Pistol Grip

- Used for tasks requiring large forces, electrical assistance provides force multiplication

✓	VERSA® HD	AVAILABLE SOON!
●		
✗	All other telemanipulators	

◆◆◆ PRICE | ◆◆◆ USAGE | ◆◆ FEEL

## Indexing

Telem manipulator indexing lets you change the relationship of the command and remote arms to improve in cell reach, or make operations easier by allowing the operator to stand in a comfortable position.

In some cases indexing in Y motion also allows the telem manipulator to be installed in or removed from a wall tube.

### Z Manual Ergonomic Adjustment

- Independent height adjustment on command arm
- Provides ergonomic comfort adjustment for operators



✓	VERSA®
●	G, L, L-HD <b>AVAILABLE SOON!</b>
✗	All other telem manipulators

◆  
PRICE

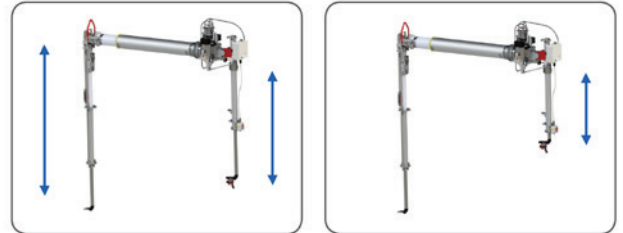

### Y Manual

- Manual Y-indexing provides 15, 30, and 45 degree command to remote indexing and is performed by moving a lever

✓	G-LD
●	G-LDR
✗	All other telem manipulators

◆  
PRICE

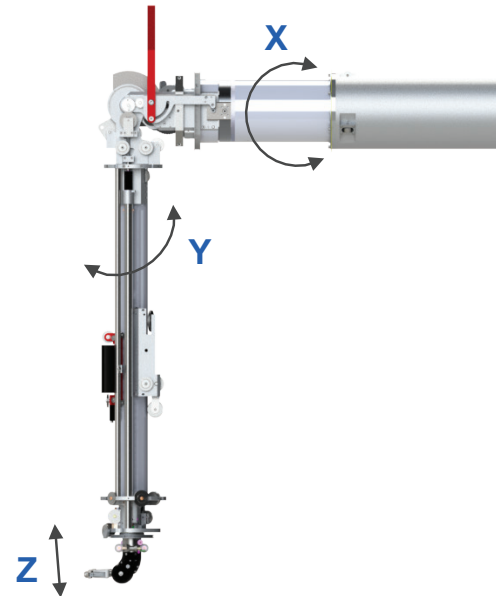

### Electrical System

- Electrical indexing uses motors and switches to control the telem manipulator indexing motions

✓	All other telem manipulators
●	
✗	G-LD, G-LDR

UL	Non-UL
◆◆◆	◆◆
PRICE	PRICE

### Electrical System - Indexing Options

#### X Electrical

- X indexing controls the left and right orientation of the remote arm

✓	All other telem manipulators
●	
✗	G-LD, G-LDR

◆◆◆  
PRICE

#### Y Electrical

- Y indexing controls the forward and back orientation of the remote arm

✓	All other telem manipulators
●	
✗	G-LD, G-LDR

◆◆◆  
PRICE

#### Z Electrical

- Z indexing (or Extension) controls the height of the remote arm in relation to the command arm

✓	E, E-HD, F, VERSA®
●	G, G-HD, L, L-HD
✗	8, 8-HD, H, G-LD, G-LDR

◆◆◆  
PRICE

### Motion Locks

Motion locks for CRL telemanipulators are used to lock the telemanipulator rigidly in any position within the dimensional limits of the telemanipulator. This allows the telemanipulator to hold an object in space without requiring an operator, and facilitates the installation and removal of the telemanipulator.

In general, motion locks come in three distinct units:

- X Motion
- Y Motion
- Z Motion, Azimuth and Elevation/Twist Rotations

The three units can be operated independently, or together (manually or pneumatically actuated).

The tong/grip lock is a part of all standard telemanipulator handle assemblies.

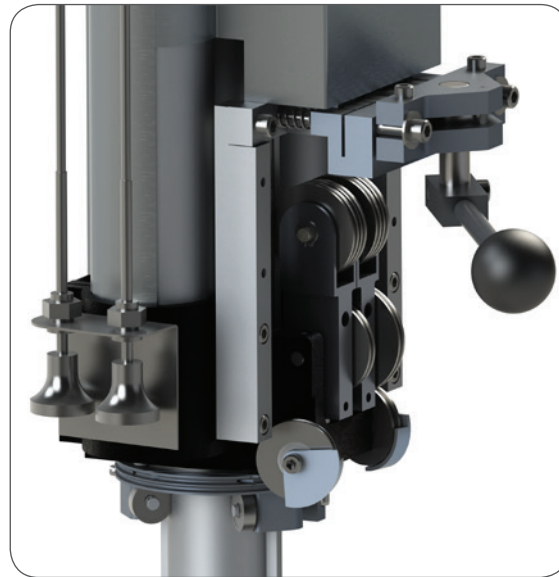

#### X Motion

- This locks the telemanipulator in position left/right

✓	All other telemanipulators
●	
✗	G-LDR

Mechanical

◆◆  
PRICE

Pneumatic

◆◆◆◆  
PRICE

#### Y Motion

- This locks the telemanipulator from moving forward or backward

✓	All other telemanipulators
●	
✗	G-LDR

Mechanical

◆◆  
PRICE

Pneumatic

◆◆◆◆  
PRICE

#### Z Motion, Azimuth and Elevation/Twist Rotations

- This locks the wrist motion, and keeps the telemanipulator from going up and down

✓	All other telemanipulators
●	
✗	G-LDR

Mechanical

◆◆  
PRICE

Pneumatic

◆◆◆◆  
PRICE

## Air Restriction

The air restriction feature reduces the air flow through the telemanipulator thru-tube. It is mounted inside the thru-tube, near the remote end, and consists of a plate with central felt wipers through which the tapes and cables operate and two cones (boot-like sleeves) through which the tie rods operate.

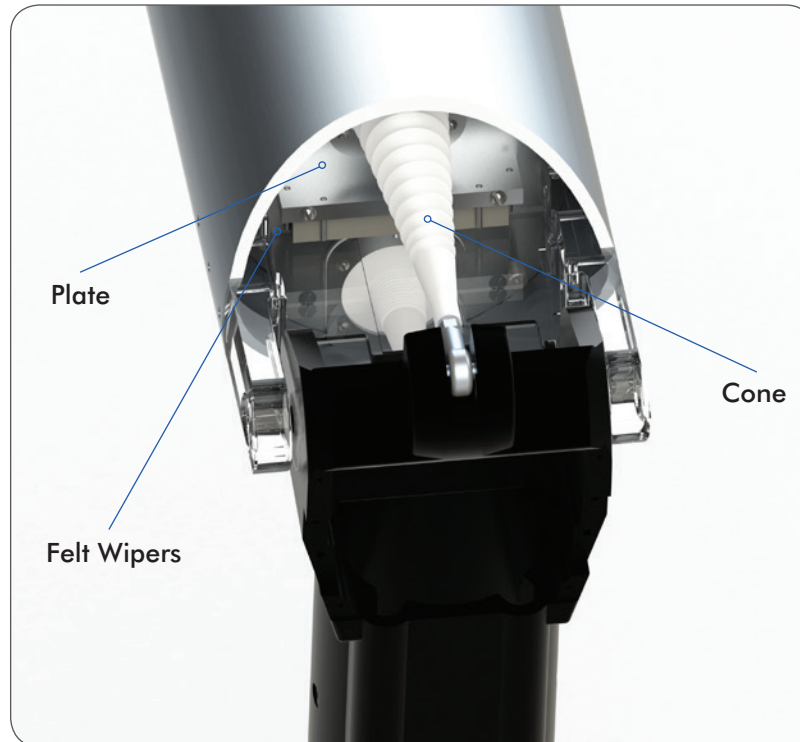

### Air Restriction

- Used in place of booting on one-piece telemanipulators

✓	
●	G-LD, G-HD, H, E, E-HD, 8, 8-HD, F
✗	L, L-HD, VERSA®, G-LDR

## Booting

A booting assembly is typically used to restrict air flow into the hot cell and to protect the remote arm from contamination. Booting can be provided as polyurethane, CSM coated polyurethane or PVC sleeve material.

For one-piece models, the tong assembly or jaws can be disconnected and entire telemanipulator removed with booting still in place and no loss of containment.

For three-piece models, the entire remote arm can be disconnected from seal tube with booting still in place.



## Material

### Poly

◆ PRICE | ◆ USAGE

### Poly CSM

◆◆ PRICE | ◆◆ USAGE

\*Poly CSM is suggested for use with harsh chemicals or cleaning agents.

## Wall Mounting Options



### Clamp to wall

- Used for one-piece

◆ PRICE

✓	G-LDR
●	
✗	All other telemanipulators



### Clamp to push-through ring

- Used for one-piece or three-piece

◆ PRICE

✓	All other telemanipulators
●	VERSA®, L, L-HD
✗	G-LDR



### Clamp to remote arm

- Used for three-piece

◆ PRICE

✓	VERSA®, L, L-HD
●	
✗	All other telemanipulators

## Tong Mounting Options



### Over Tong

✓	SRL Tongs with non-removable wrist
●	Power Tong
✗	All other tongs

◆ PRICE | ◆ USAGE | ◆ FEEL



### Boot/Tong Adapter

✓	RCD Tongs with non-removable wrist
●	
✗	All other tongs

◆ PRICE | ◆ USAGE | ◆ FEEL



### Boot/2-piece Tong

✓	Small & Large 2-piece Tongs
●	
✗	All other tongs

◆◆ PRICE | ◆◆ USAGE | ◆◆◆ FEEL



### Boot/3-piece Tong

✓	Small & Large 3-piece Tongs
●	
✗	All other tongs

◆◆◆ PRICE | ◆◆ USAGE | ◆◆◆ FEEL



### Boot/Removable Wrist

✓	SRL & Power Tongs with removable wrist
●	
✗	

◆◆ PRICE | ◆◆◆ USAGE | ◆◆◆ FEEL

## Installation/Removal Carts

The Installation/Removal Cart is a multipurpose system which can be used for the installation and removal of telemanipulators. The system consists of a transportation cart and a lift carriage, which allows the units to be moved horizontally and vertically for proper alignment during installation and removal process.



### Large Cart

- Typically used for heavy-duty units with high mounting heights

✓	E, E-HD, F, 8, 8-HD, VERSA®
●	G, G-HD, L, L-HD
✗	G-LD, G-LDR

### Small Cart

- Typically used for light duty units with low mounting heights

✓	G, G-HD, G-LD, G-LDR
●	
✗	E, 8, F, VERSA®, L



## Storage Carts

- For storage use of one or two telemanipulators
- Variable heights available to accommodate all telemanipulators

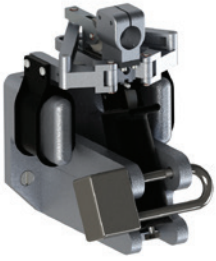

### ***Tamper Lock***

Tamper locks can be used to lock the telemanipulator handle to the cell wall and prevent damage to the telemanipulator or in-cell equipment by unauthorized operators.

### ***Load Hook***

The Load Hook accessory is a remotely removable device that hangs from the end of the telemanipulator remote arm. Its hook is used to pick up objects that are normally too heavy or awkward to handle in the tongs.

\*Not available on G-LDR

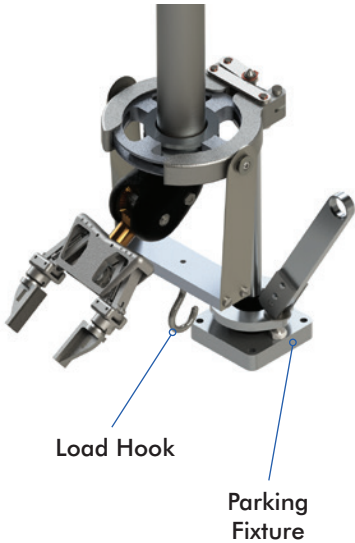

### ***Parking Fixture***

The Parking Fixture is used to install and remove the Load Hook. It is also used to store the Load Hook when not in use.

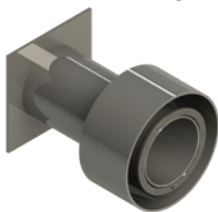
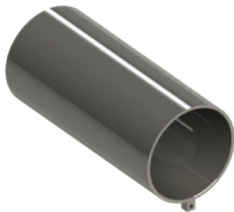
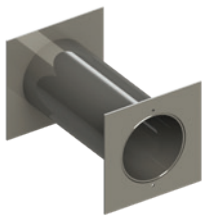

### ***Wall Tubes***

Wall tubes for accepting and mounting telemanipulators are available in a variety of lengths, styles and materials. This includes choices for flanges and bag-out recesses.

## Jaws

Various styles of jaws are available to handle a wide variety of shapes, types of loads, and application uses. Custom jaws can also be designed to accommodate specific application needs.



**File Face Jaw**

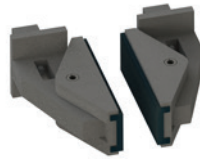

**Pivoting Finger Jaw**



**Vial Jaw**

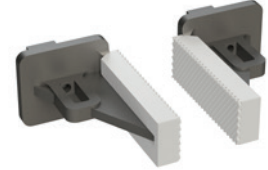

**Removable-Pad Jaw**

- Available Pad Material: Buna-N or Ura-Rad

- Available Pad Material: CSM, Silicone, Buna-N

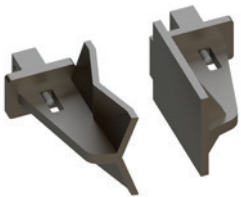

**18° Vee & Flat Jaw**



**Extended Removable-Pad Jaw**

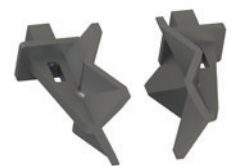

**30° Vee Jaw**



**Extended 30° Vee Jaw**

- Available Pad Material: CSM, Silicone, Buna-N

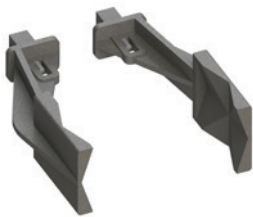

**Extended 18° Vee Jaw**



**Pivoting Finger File Face Jaw**

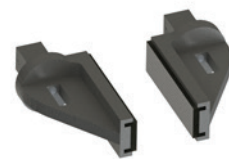

**Standard Jaw**

- Buna-N Pad Material

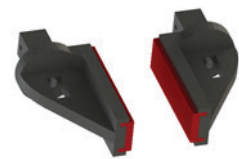

**Standard Jaw**

- Ura-Rad Pad Material



**Telemanipulator Type:**

- One-piece    Three-piece

**Handling Capacity:** \_\_\_\_\_ lb (kg)

- Intermittent    Continuous    Heavy

**Telemanipulator Size:**

Cell dimensions: L \_\_\_\_\_

W \_\_\_\_\_

H \_\_\_\_\_

**One-piece Telemanipulator:**

- G-LDR    G-LD    H

- G-HD    E    8

- E-HD    8-HD    F

**Three-piece Telemanipulator:**

- L    L-HD    VERSA® HD    VERSA® MD

**Radiation Shielding:**

- Internal

Laminated    Lead    Stainless Steel    Borinated Poly

Labyrinth    Lead    Stainless Steel    Borinated Poly

- External

Laminated    Lead    Stainless Steel    Borinated Poly

Labyrinth    Lead    Stainless Steel    Borinated Poly

Penetration Hole Size    Ø4.76    Ø7.5    Ø10    Custom \_\_\_\_\_

**Tong/Jaws:**

SRL tong    Aluminum    Stainless Steel

RCD tong    Aluminum    Stainless Steel

Power tong    Aluminum    Stainless Steel

Small 2-piece tong    Large 2-piece tong   |    Small 3-piece tong    Large 3-piece tong

**Wrist:**

Removable    Tape    Cable    Chain

Non-Removable    Tape    Cable    Chain

**Variable Z Ratio:**

- 4:3    1.5:1

**Handle Options:**

- Opposed Grip  
 Pistol Grip  1-speed  2-speed (Ratchet)  
 Motion Grip  
 VERSA® VR8  Opposed

**Indexing:**

- Y Manual  Z Manual  
 Electrical System  
 X Electrical  Y Electrical  Z Electrical

**Locks:**

- X Motion  Y Motion  Z Motion, Azimuth and Elevation/Twist Rotations  
 Mechanical  Pneumatic

 **Air Restriction****Booting:**

- One-piece Telemanipulator  Three-piece Telemanipulator  
 Poly  Poly CSM  
 Wall Attachment  Clamp to wall  Clamp to push-through ring  Clamp to remote arm  
 Tong Attachment  Over Tong  Boot/Tong Adapter  Boot/2-piece Tong  Boot/3-piece Tong  
 Boot/Removable Wrist

***Accessories***

**Installation/Removal Cart:**  Large Cart  Small Cart

- Storage Cart**  
 **Tamper Locks**  
 **Load Hook**  
 **Parking Fixture**  
 **Wall Tube**

**Jaws**  File Face  Pivoting Finger (Buna-N)  Pivoting Finger (Ura-Rad)  Removable-Pad  
 18° Vee & Flat  Extended Removable-Pad  30° Vee  Extended 30° Vee  Extended 18° Vee  
 Pivoting Finger File Face  Standard Jaw (Buna-N)  Standard Jaw (Ura-Rad)



***CRL Headquarters/Support***

3965 Pepin Avenue  
Red Wing, MN 55066  
Tel: +1-651-385-2142  
Toll Free: +1-800-934-1562  
info@crlsolutions.com

***crlsolutions.com***